

**O QUE UM
ENGENHEIRO QUÍMICO
VEIO FAZER EM UM
TIME DE AGILE
COACHES?**



PANDA | ANTONIO GERENT

**AGILE COACH
ENGENHEIRO QUÍMICO
PÓS EM ENGENHARIA DE PRODUÇÃO
11 ANOS DE EXPERIÊNCIA COM
LEAN NA INDÚSTRIA**



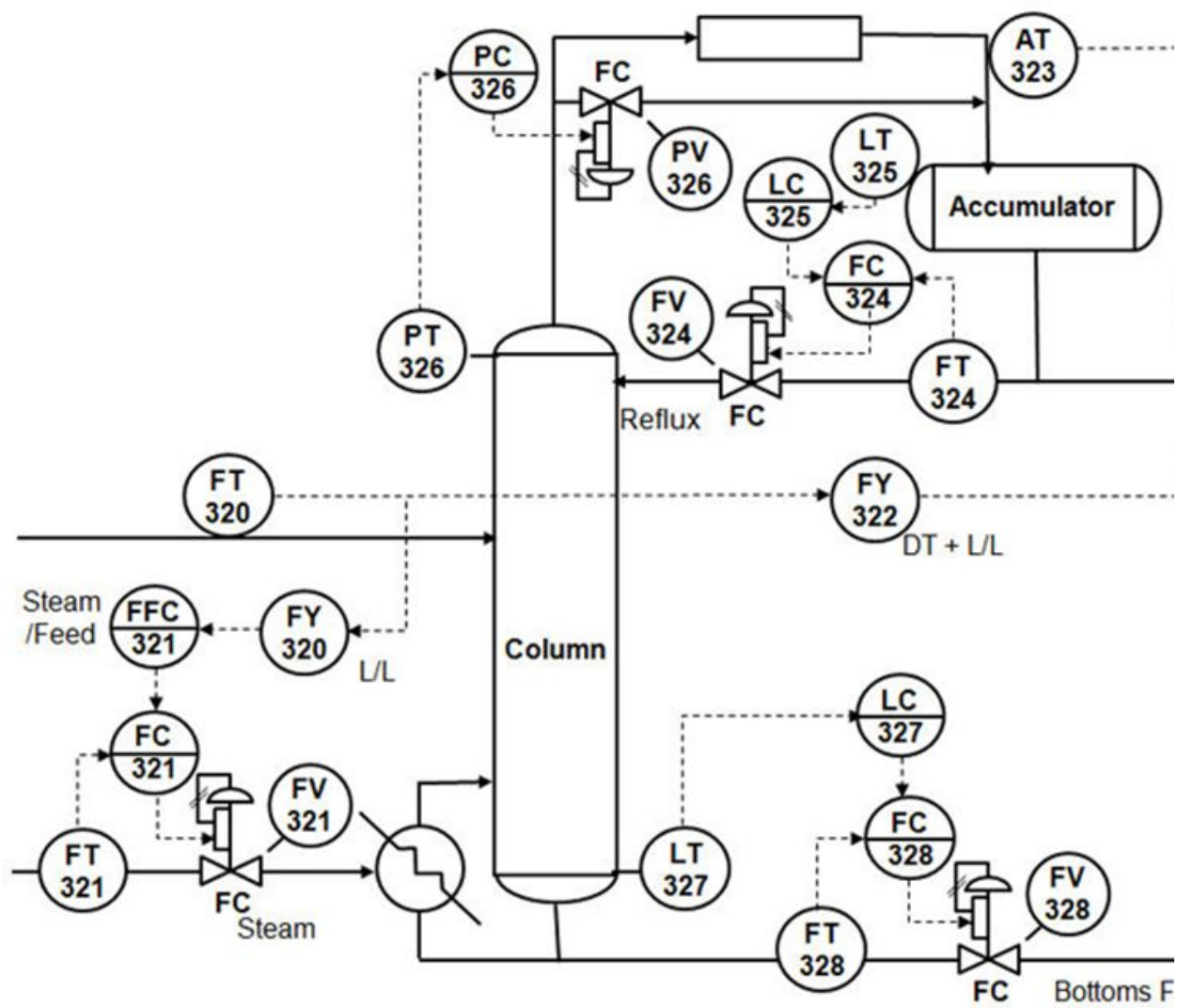





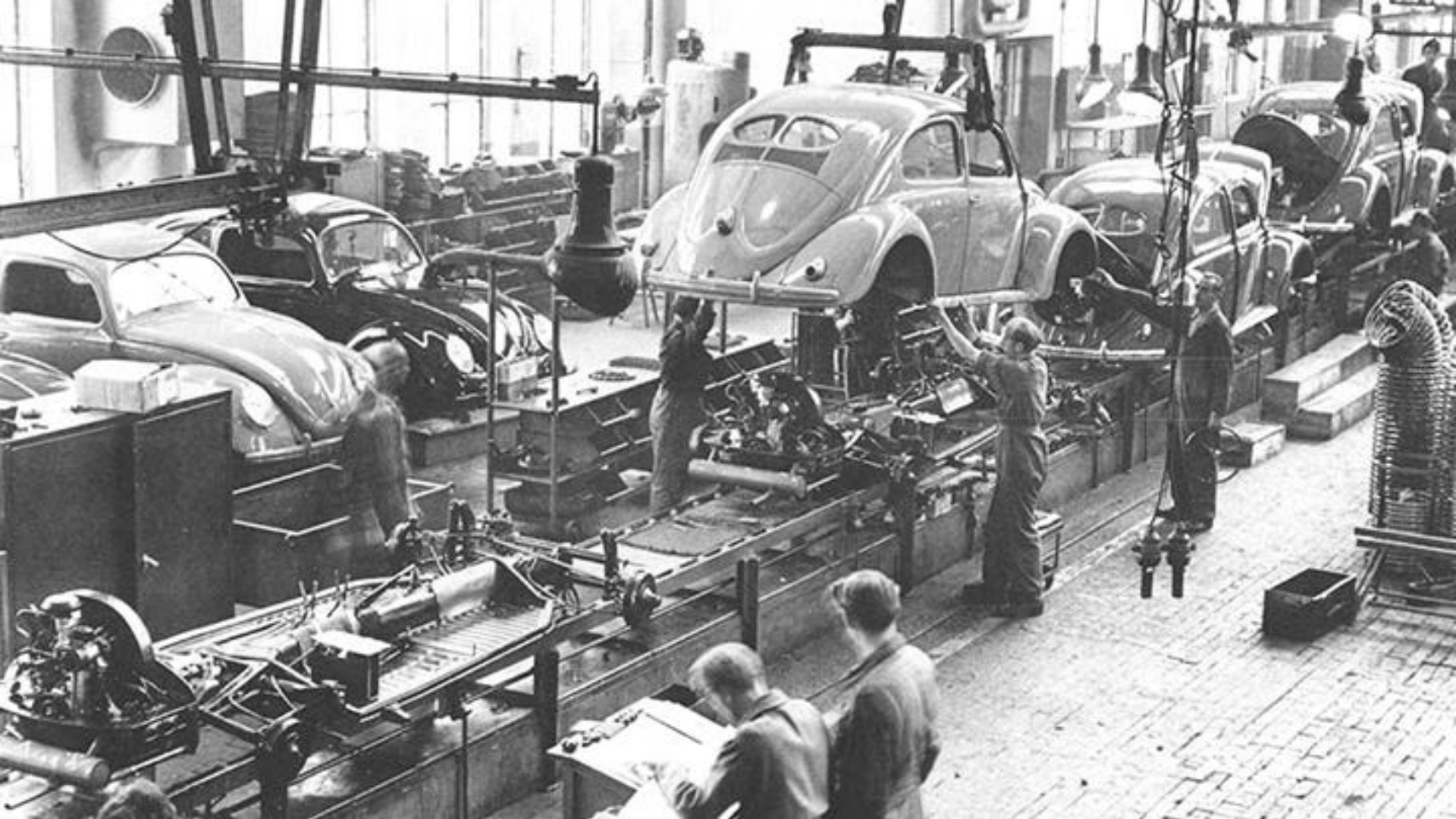



dica
quente!

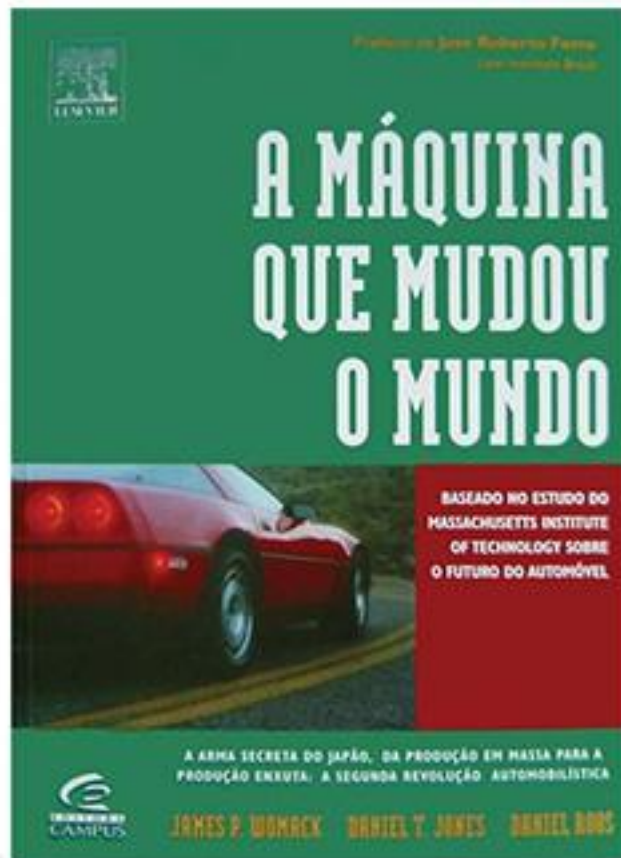

UM BELO DIA...

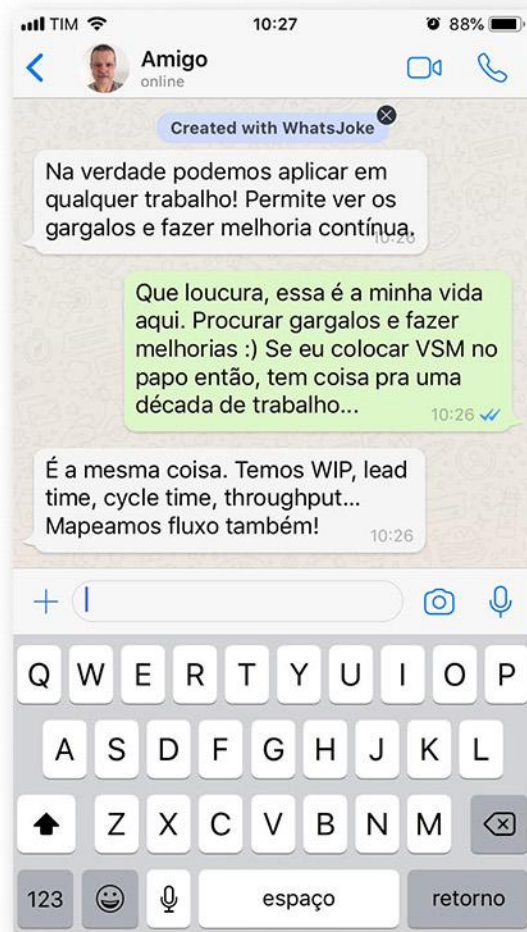
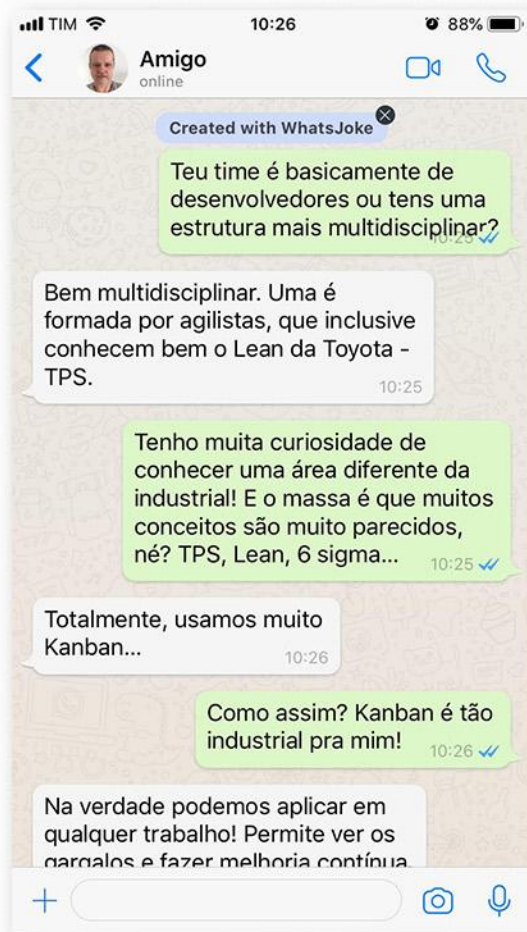





Filho,

o que você

faz da vida?

Ass: mamãe

Sean,
o que você
faz da vida?

DEFINIR LEAN É ÚTIL, DEFINIÇÕES DE LEAN SÃO INÚTEIS.

[RUSSELL WATKINS]

ELIMINAÇÃO DE DESPERDÍCIO E REDUÇÃO DE CUSTO (E REDUZIR LEAD TIME);

ALINHAMENTO DO ESFORÇO DO CLIENTE ATÉ O CHÃO DE FÁBRICA E TODOS ENTRE ELES;

SENSIBILIDADE DO GEMBA ORIENTADO AO CLIENTE E COLABORAÇÃO PARA ENTREGA DE VALOR.

**“NÓS FAZEMOS AS COISAS COM ORGULHO, DA FORMA MAIS
SIMPLES E QUE NOSSOS CLIENTES AMAM.”
(CRIANÇA DE 9 ANOS)**

FILOSOFIA



MÉTODO



FERRAMENTAS

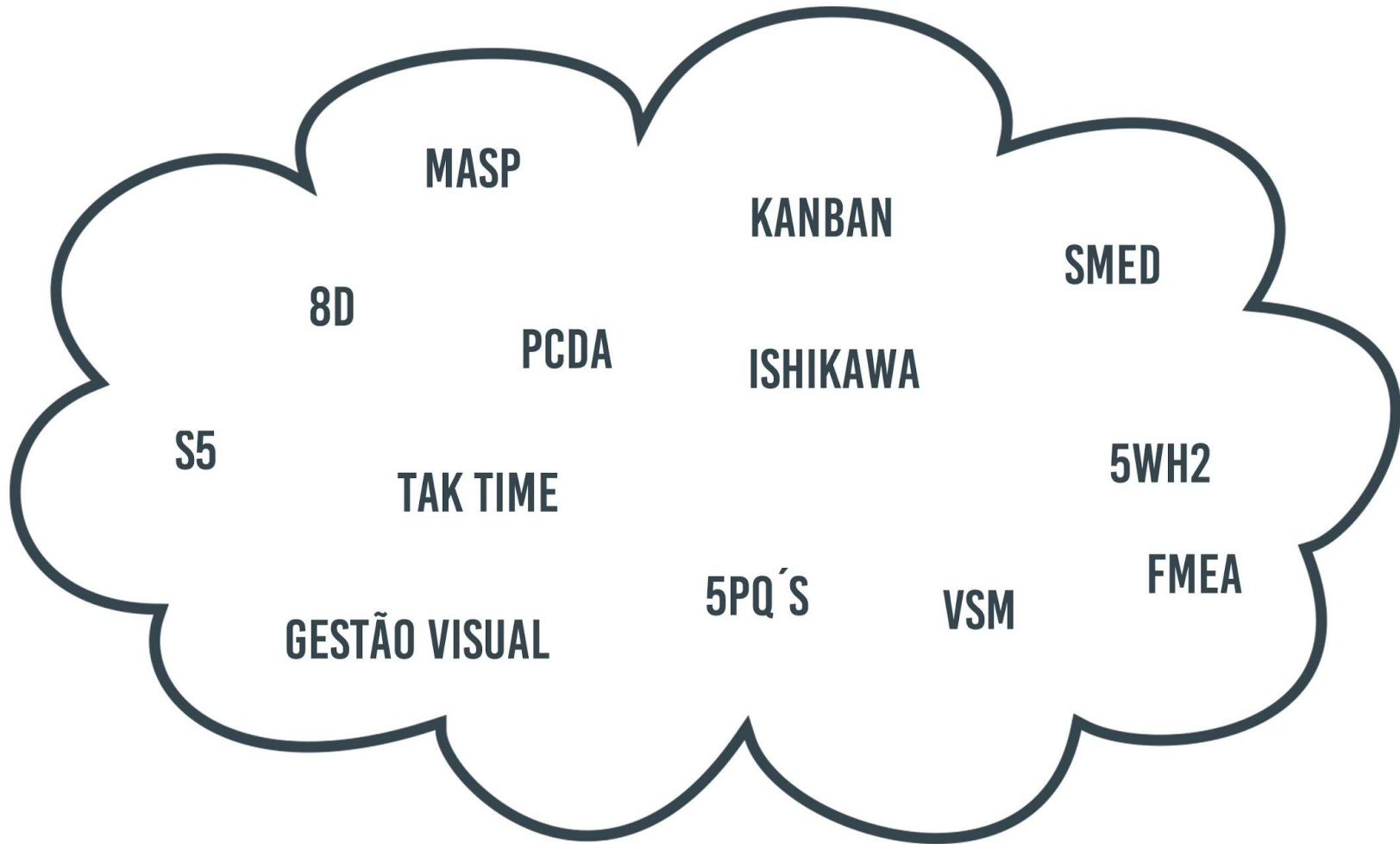



1966-1968

UTILITY BELT

OUR CAPED CRUSADER'S GREATEST TOOL IN THE ONGOING FIGHT AGAINST CRIME!

EPISODE NUMBER



SEASON 1



SEASON 2



SEASON 3



1 BATARANG



10 BAT-SHIELD



1 BAT-HOOK



1 BAT-CUFFS



2 LASER GUN



2 BAT-GAUGE



3 SMOKE PELLETS
11 ANTI-MESMERIZING BAT-REFLECTOR



14 BAT HOMING TRANSMITTER



12 BAT-COMMUNICATOR



15 BINOCULARS



20 CLIMBING CLAWS



13 BAT-KEY



3 ADHESIVE BAT-BOMB



POUCHES FOR STORAGE



ADDITIONAL STORAGE



5 MAGNIFYING GLASS



17 BAT-FUNNEL



16 LIVE FISH



4 UNIVERSAL DRUG ANITDOTE PILL
18 BAT PILL



6 SHARK REPELLANT



7 ANTI-LETHAL FOG BATS-SPRAY



8 ANTI-BLAST BAT POWDER



9 BATNESIA GAS

**E O TRABALHO
DO CONHECIMENTO?**

INFORMAÇÃO (INVISÍVEL)



MATERIAIS (FÍSICO)



COMPLEXIDADE

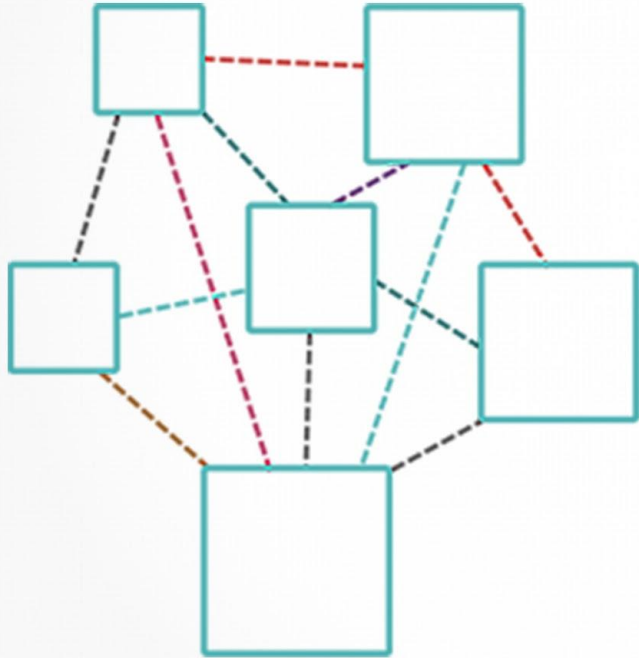

VARIABILIDADE



NA PRÁTICA

A TEORIA É

OUTRA





**NO TIME DE OPERAÇÕES,
DEVO FOCAR NA REDUÇÃO
DE DESPERDÍCIO OU
NO PROPÓSITO?**

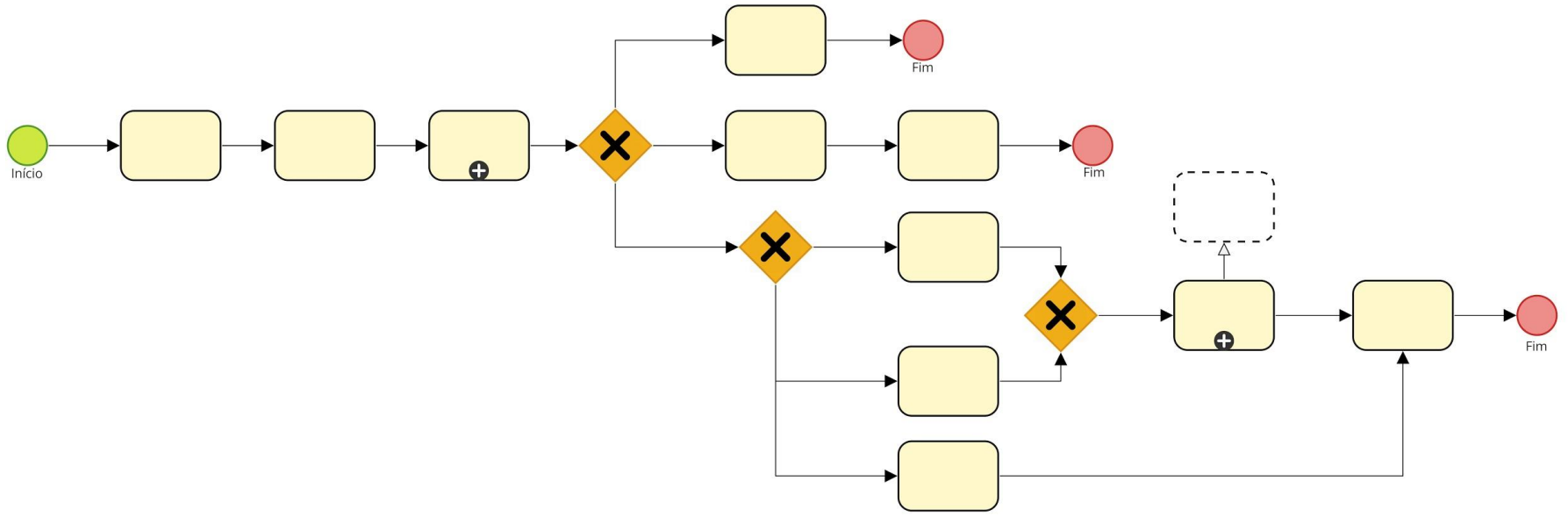

"ASSIM COMO UM CARPINTEIRO
PRECISA DE UMA VISÃO DO QUE
CONSTRUIR, A FIM DE OBTER O PLENO
BENEFÍCIO DE UM MARTELO,
OS PENSADORES LEAN PRECISAM DE
UMA VISÃO ANTES DE PEGAR NAS
FERRAMENTAS LEAN".

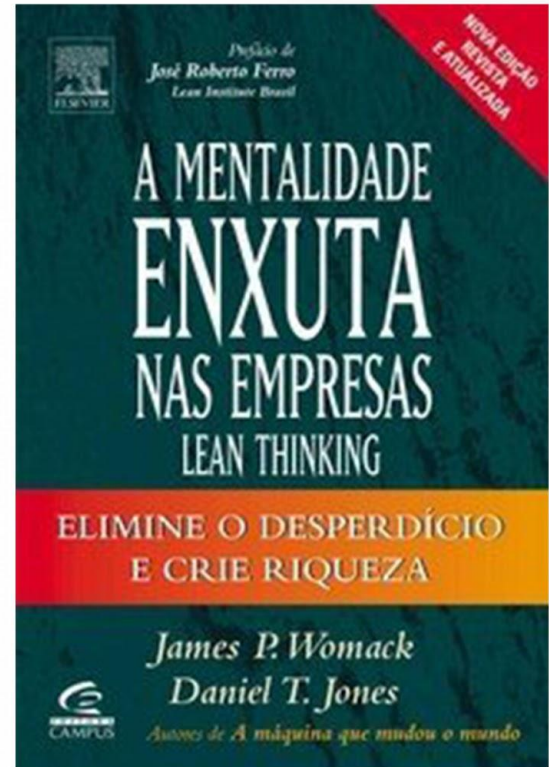

COMECE

COMO GRANDES LÍDERES INSPIRAM
PESSOAS E EQUIPES A AGIR

PELO

SIMON SINEK

PORQUÊ

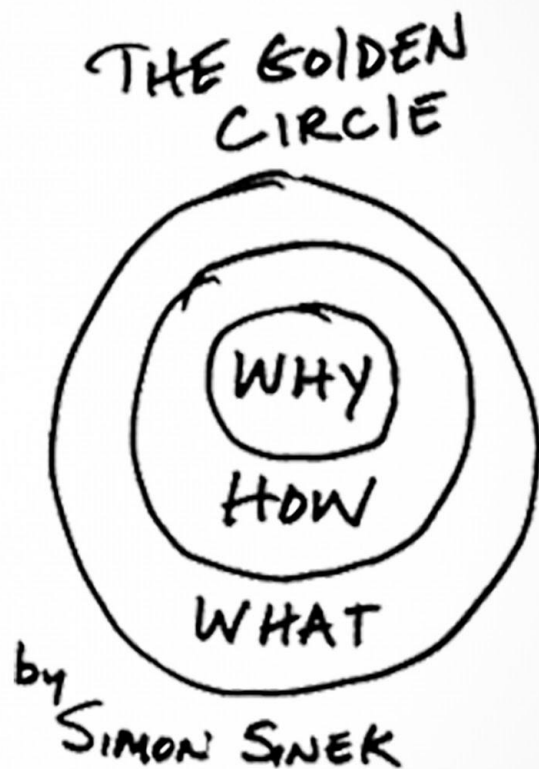

To do

Work

Testing

Done



Doing

Done

Doing

Done



Urgent Tasks





**NO TIME DE ATENDIMENTO,
DEVO FOCAR NA
EFICIÊNCIA OU NA
CADEIA DE VALOR?**

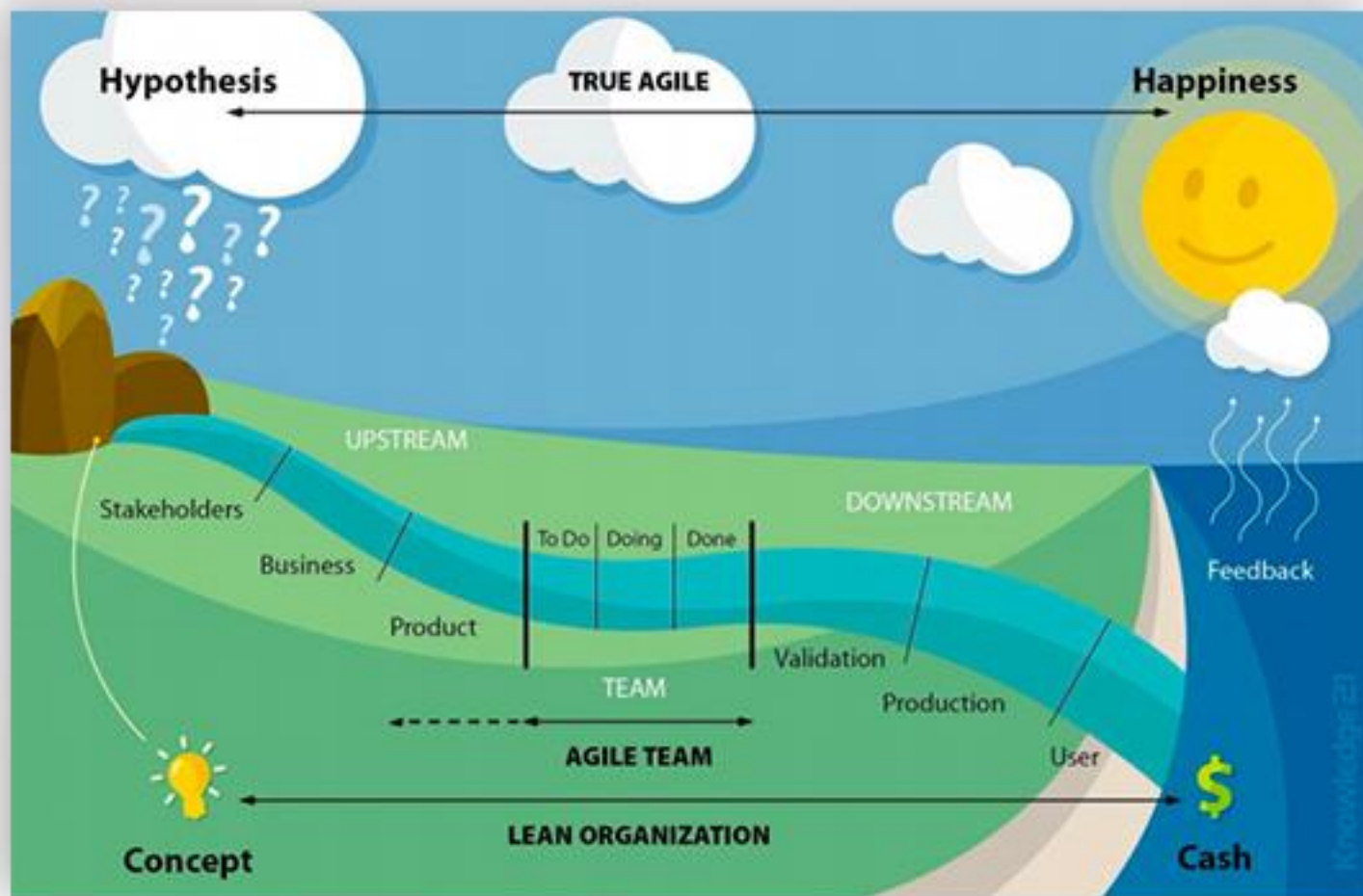

To do

Work

Testing

Done



Doing

Done

Doing

Done



Urgent Tasks



IMPROVEMENT THEME

NOW/PROBLEM

NEXT TARGET
CONDITION

6 weeks from now:

DEFINITION OF
AWESOME

o -----
o -----
o -----
o -----

FIRST STEPS



The
Pragmatic
Programmers

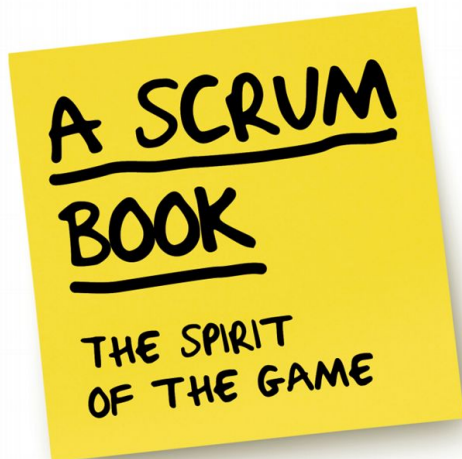

Jeff Sutherland
James O. Coplien
The Scrum Patterns Group
edited by Adaobi Obi Tulton

A Scrum Book

The Spirit of the Game

Jeff Sutherland
James O. Coplien

Lachlan Heasman
Mark den Hollander
Cesário Ramos

and The Scrum Patterns Group:

Esther Vervloed, Neil Harrison, Kiro Harada, Joseph Yoder,
June Kim, Alan O'Callaghan, Mike Beedle, Gertrud Bjørnvg,
Dina Friis, Ville Reijonen, Gabrielle Benefield, Jens Østergaard,
Veli-Pekka Eloranta, Evan Leonard, and Ademar Aguiar

The Pragmatic Bookshelf

Raleigh, North Carolina

STATIK - SYSTEMS THINKING APPROACH TO INTRODUCING KANBAN

1. PROPÓSITO: ENTENDA QUEM É O SEU CLIENTE E O QUE SIGNIFICA SUCESSO PRA ELE
2. INSATISFAÇÕES: A BASE DA EVOLUÇÃO
3. ANÁLISE DA DEMANDA: TRABALHO EM PROGRESSO
4. ANÁLISE DA CAPACIDADE (OU FALTA DELA)
5. WORKFLOW: CONHECIMENTO AO LONGO DO TEMPO
6. CLASSES DE SERVIÇO – WTF?
7. DESIGN KANBAN SYSTEM – MODELANDO O SISTEMA
8. ROLLOUT – BORA COLOCAR O SISTEMA KANBAN PRA RODAR!



LUIZ LULA RODRIGUES
K21

**TIME DE
DESENVOLVIMENTO:
O DESAFIO ATUAL!**





**OBSERVE.
PERGUNTE: POR QUÊ?
DEMONSTRE RESPEITO.**



**COMO FICA UM PARALELO
ENTRE LEAN E KANBAN?**



LEAN: PRINCÍPIOS

FILOSOFIA DE LONGO PRAZO

O PROCESSO CERTO PRODUZIRÁ OS RESULTADOS CORRETOS

AGREGUE VALOR À ORGANIZAÇÃO DESENVOLVENDO SUAS
PESSOAS E PARCEIROS

RESOLVER CONTINUAMENTE PROBLEMAS DE RAIZ
IMPULSIONA A APRENDIZAGEM ORGANIZACIONAL

KANBAN: PRINCÍPIOS



COMECE COM O QUE VOCÊ FAZ AGORA
CONCORDE NA BUSCA DA MELHORIA ATRAVÉS DE MUDANÇAS EVOLUTIVAS
INCENTIVE ATOS DE LIDERANÇA EM TODOS OS NÍVEIS, DESDE O COLABORADOR
INDIVIDUAL ATÉ A GERÊNCIA SÊNIOR

ENTENDA E CONCENTRE-SE NAS NECESSIDADES E EXPECTATIVAS DO CLIENTE
GERENCIE O TRABALHO, DEIXE AS PESSOAS SE ORGANIZAREM EM TORNO DELE
POLÍTICAS CONTROLAM A ENTREGA DO SERVIÇO

LEAN: PRÁTICAS

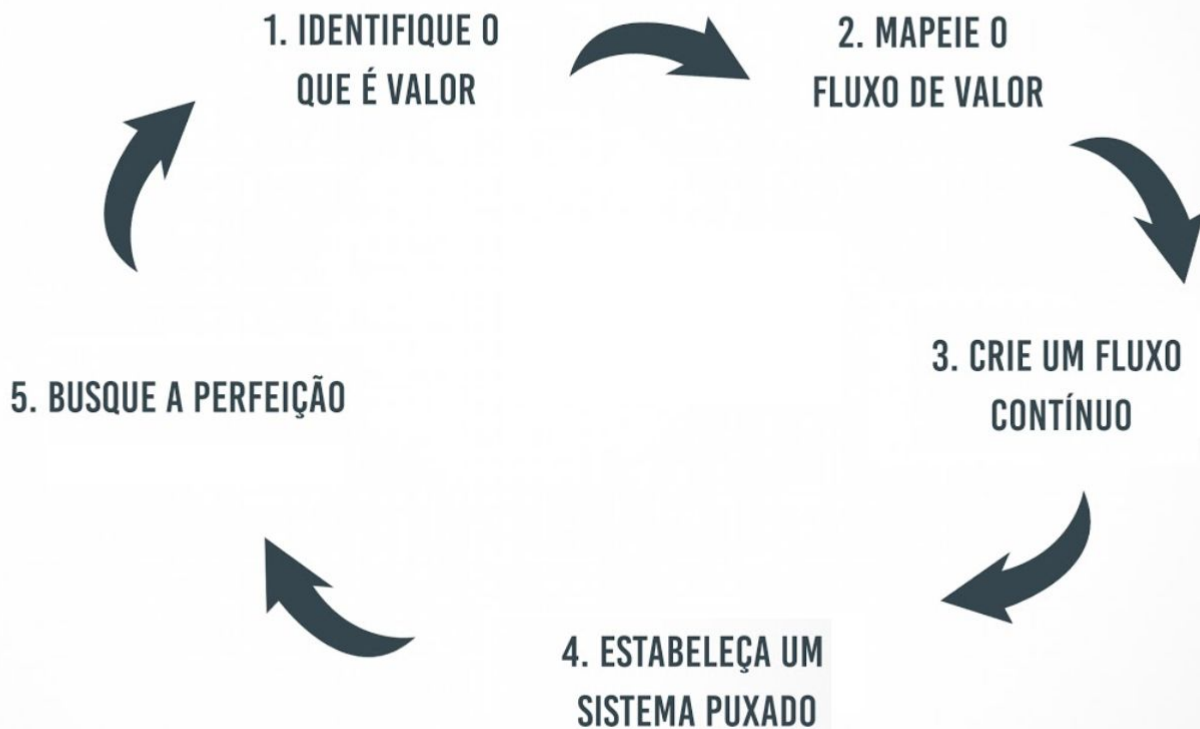

KANBAN: PRÁTICAS



- VISUALIZE
- LIMITE O TRABALHO EM PROGRESSO
- GERENCIE O FLUXO
- TORNE AS POLÍTICAS EXPLÍCITAS
- IMPLEMENTE CICLOS DE FEEDBACK
- MELHORE COLABORATIVAMENTE, EVOLUE EXPERIMENTALMENTE

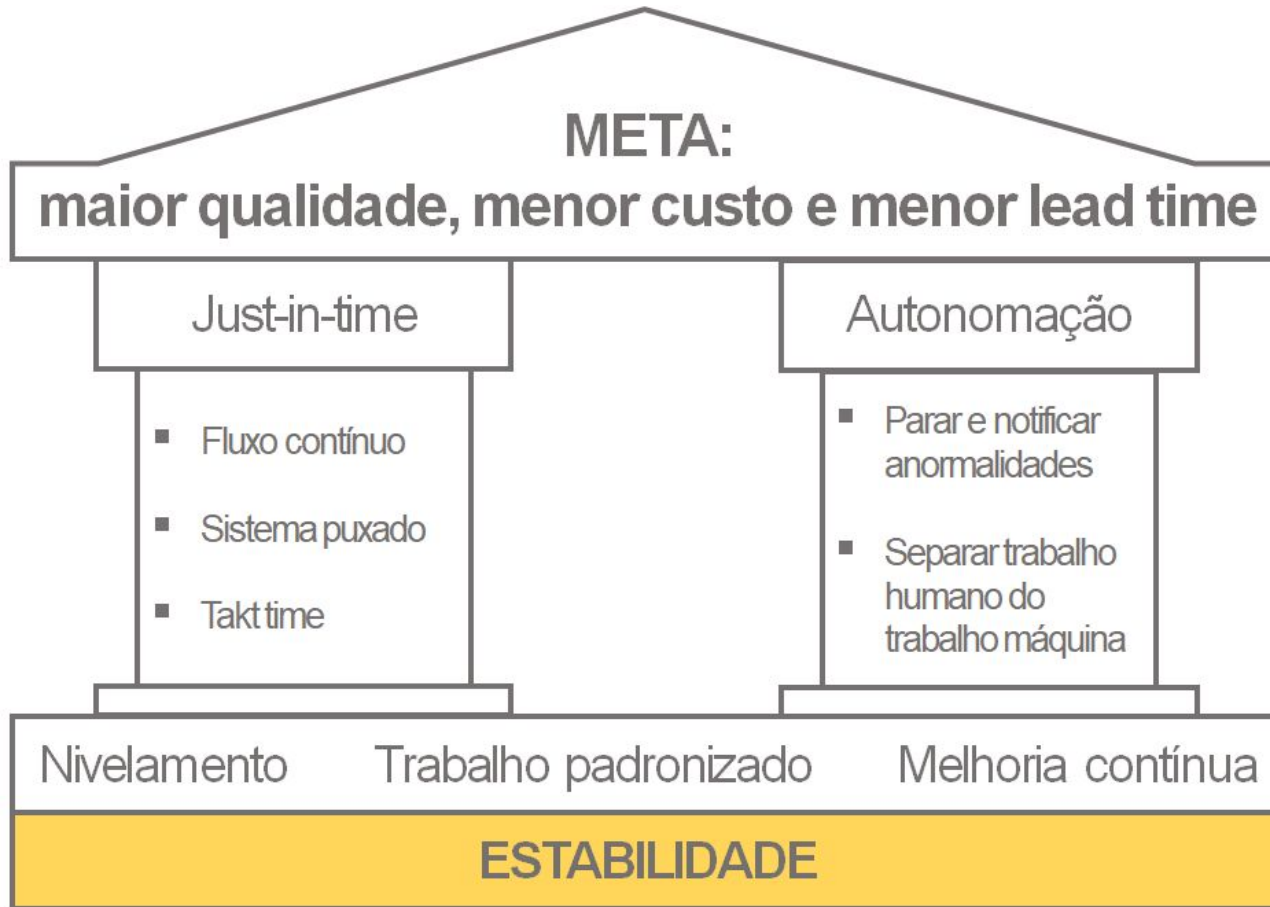

dica quente!



DAVID J. ANDERSON

ANDY CARMICHAEL

**PANDA,
O QUE POSSO LEVAR
DE TUDO ISSO?**





PROPÓSITO, PROCESSOS E PESSOAS



MELHORIA CONTÍNUA



dica
quente!

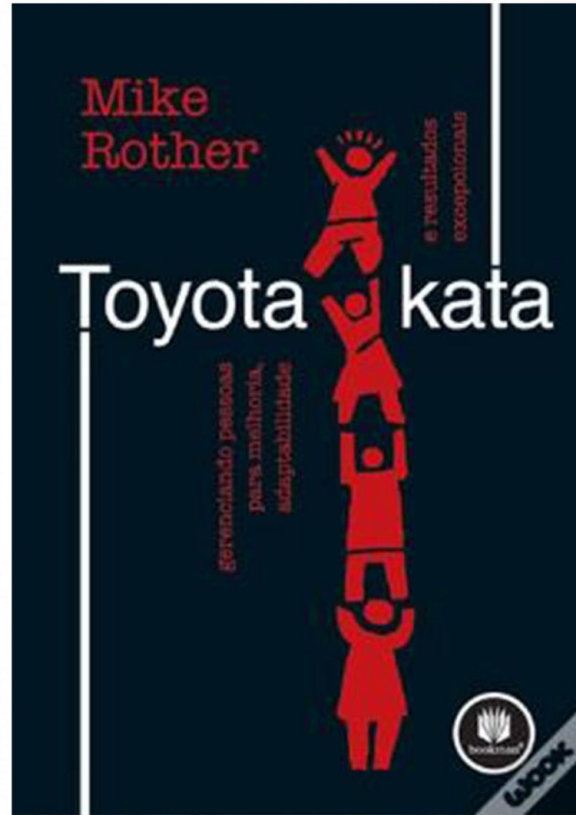

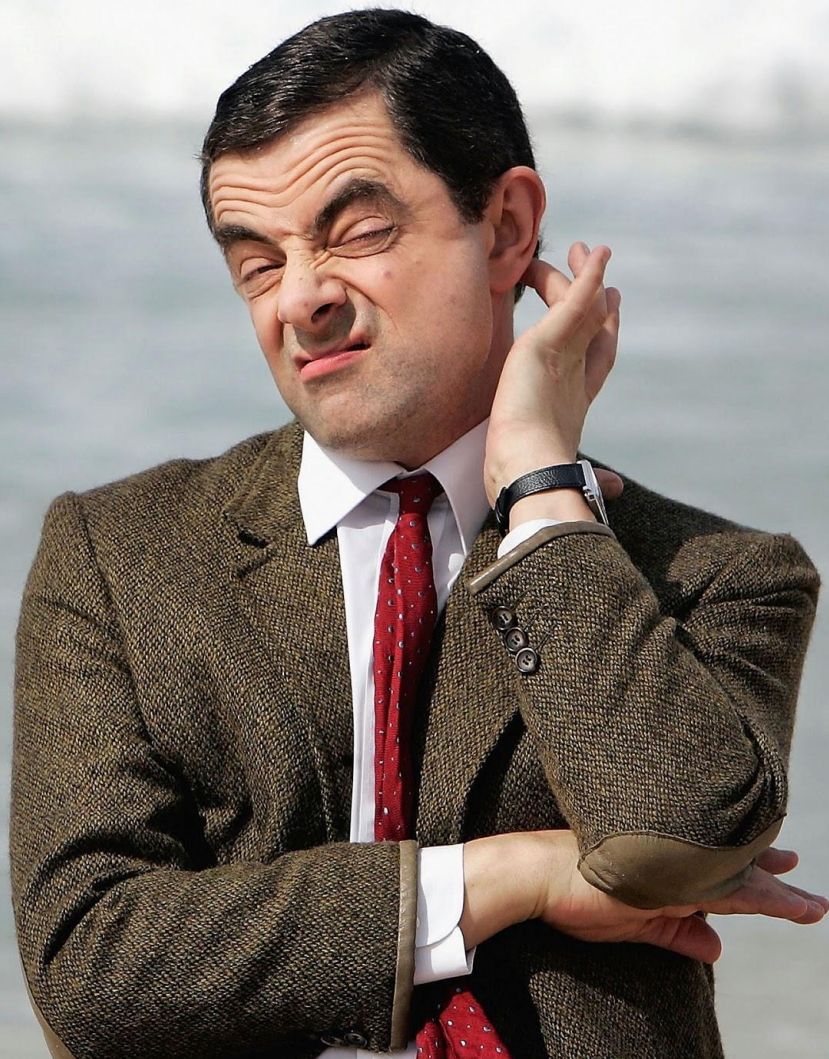

**DÁ PARA LEVAR
ESSES APRENDIZADOS
E PRÁTICAS
DA TECNOLOGIA
DE VOLTA PARA
A INDÚSTRIA?**

**SEJA DURO COM O PROCESSO,
MAS GENTIL COM OS OPERADORES.**

TOYOTA



-  **PAPOLEAN**
-  **PAPOLEAN**
-  **PAPOLEAN**

OBRIGADO!

-  **PANDAREALOFICIAL**
-  **ANTONIOGERENT**
-  **ANTONIOGERENT**